

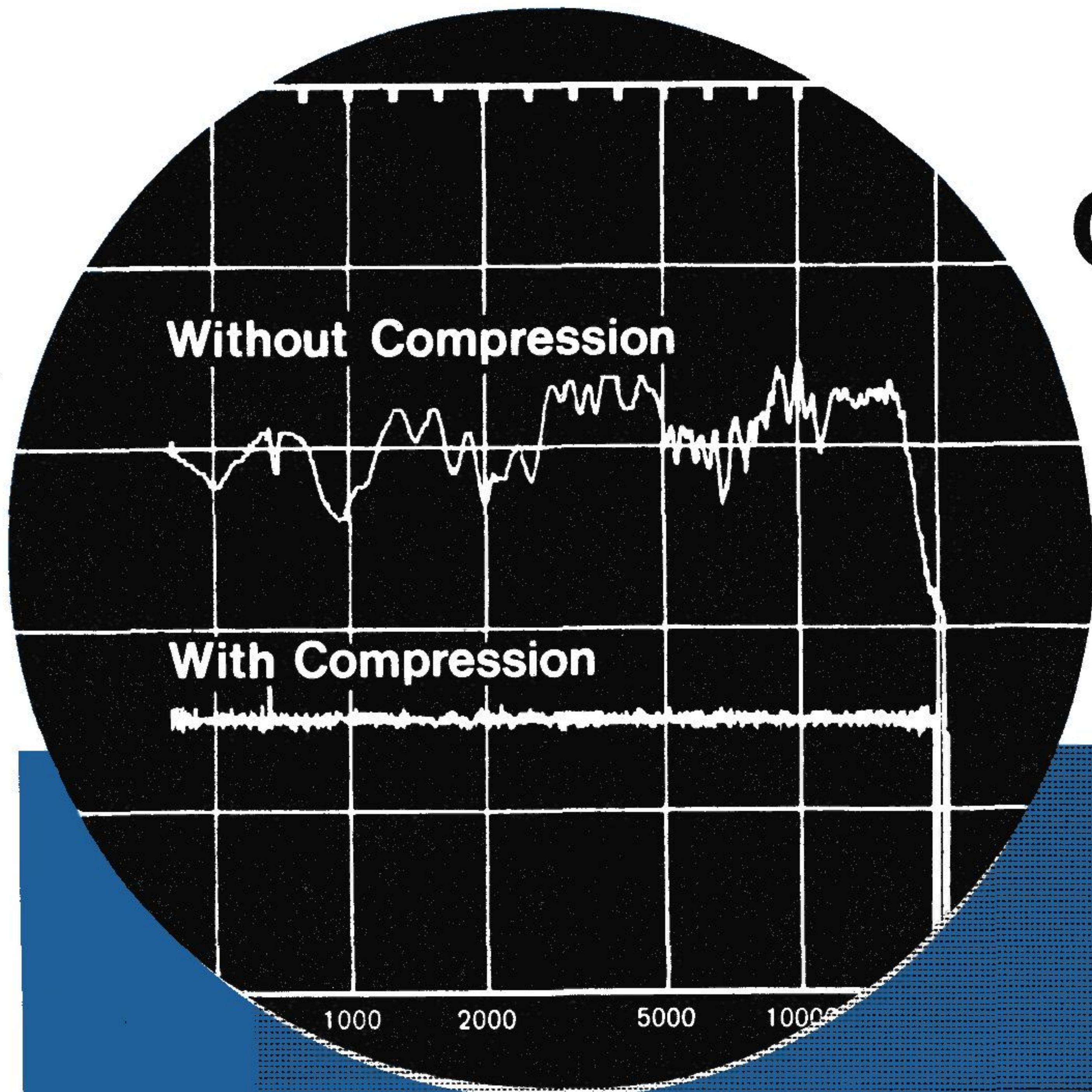

B&K Instruments, Inc.
Brüel & Kjær Precision Instruments

**application
notes**



Combination of Gating and Compression Techniques in Electroacoustic Measurements



Combination of Gating and Compression Techniques in Electroacoustic Measurements

by *Pierre Bernard*, B & K

Introduction

Compression techniques are common practice in measuring systems where the excitation signal is permanently applied. A control signal proportional to some quantity (voltage, sound pressure, vibration acceleration, etc.) is fed to the compressor of the generator which regulates the output signal so that the control signal is kept constant.

In tone-burst measurements, the signal cannot be fed directly to the

compressor input because of the absence of signal between the pulses. However, if the tone-bursts are long enough (typically longer than 30 ms), direct regulation on the pulse is possible when using a switching device to feed the compressor with a known signal on which the compressor can stabilize. This technique is described in the B & K Application Note 15—127, (Ref.1).

In many measurement situations, however, the pulse is much shorter (typically a few milliseconds). This is for example, the case in electroacoustic measurements and hydrophone measurements.

A method allowing to apply compression techniques when using short tone-bursts is described in the following. Practical applications to microphone measurements are also described.

Principle

The basic excitation system (with compressor loop) is shown in Fig.1. The Gating System Type 4440 receives the Generator signal and produces tone-bursts of adjustable length and repetition rate. A zero crossing detector ensures transient-free tone-bursts. The delay and width of the receiving gate of the 4440 are also adjustable to allow measurement on the steady-state part of the received pulse.

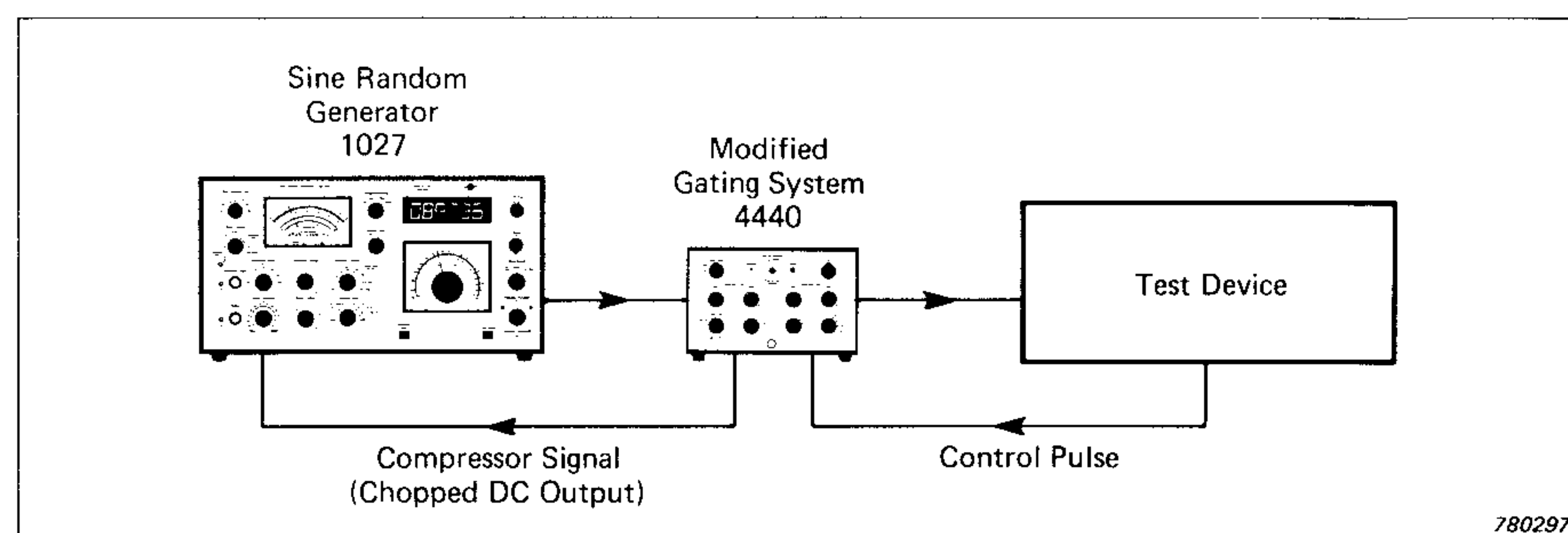

Fig.1. Basic excitation system for tone-burst measurements using compression technique

The DC output of the Gating System delivers a DC signal which is equal to the max. peak value of the measured pulse. This signal is available for the whole period between two pulses. In order to feed the compressor with an AC signal, a chopper is placed at the DC output of the 4440. In this way, the compressor receives a permanent AC signal. However, the level remains constant between two pulses. It is therefore necessary to examine this "staircase" process in some detail in order to specify the optimum working conditions.

For simplicity, the problem will first be discussed making the following assumptions: 1) after the compressor has balanced, the gain of the system is given a new, constant value and 2) there is no time delay between transmitted and received bursts. The influence of continuously varying gain is discussed in Appendix A and the influence of time delay is discussed in Appendix B. It is shown that both effects have

a negligible influence in most practical situations.

Since the input level to the compressor is constant between two sampling points (period T), the rate of change of the compressor (S, in dB/s) is also constant over T. From section 6.3 of the 1027 Instruction Manual, S can be written as:

$$S = 2C (1 - x) \quad (1)$$

With

$$x = \frac{V}{V_B}$$

C = compressor speed (dB/s) as selected on the generator

V = input voltage to the compressor

V_B = balance voltage of the compressor

Assuming that the voltage ratio is equal to x_n at the beginning of a sampling period, the level difference between the beginning and the end of the period will be:

$$\Delta_n = 2CT (1 - x_n) \quad (2)$$

At the beginning of the next period the voltage ratio at the chopper output becomes x_{n+1} , following the relationship:

$$20 \log_{10} x_{n+1} = 20 \log_{10} x_n + 2CT (1 - x_n) \quad (3)$$

or

$$x_{n+1} = x_n \exp. [a(1 - x_n)] \quad (4)$$

with

$$a = \frac{CT}{10M}$$

$$M = \log_{10} e \approx 0,434$$

Note: With B & K Generators, the above calculation is only valid for $x < 2$ (level difference < 6 dB). When x is greater than 2, the rate of change becomes constant due to clipping in the compressor amplifier and is the same as when

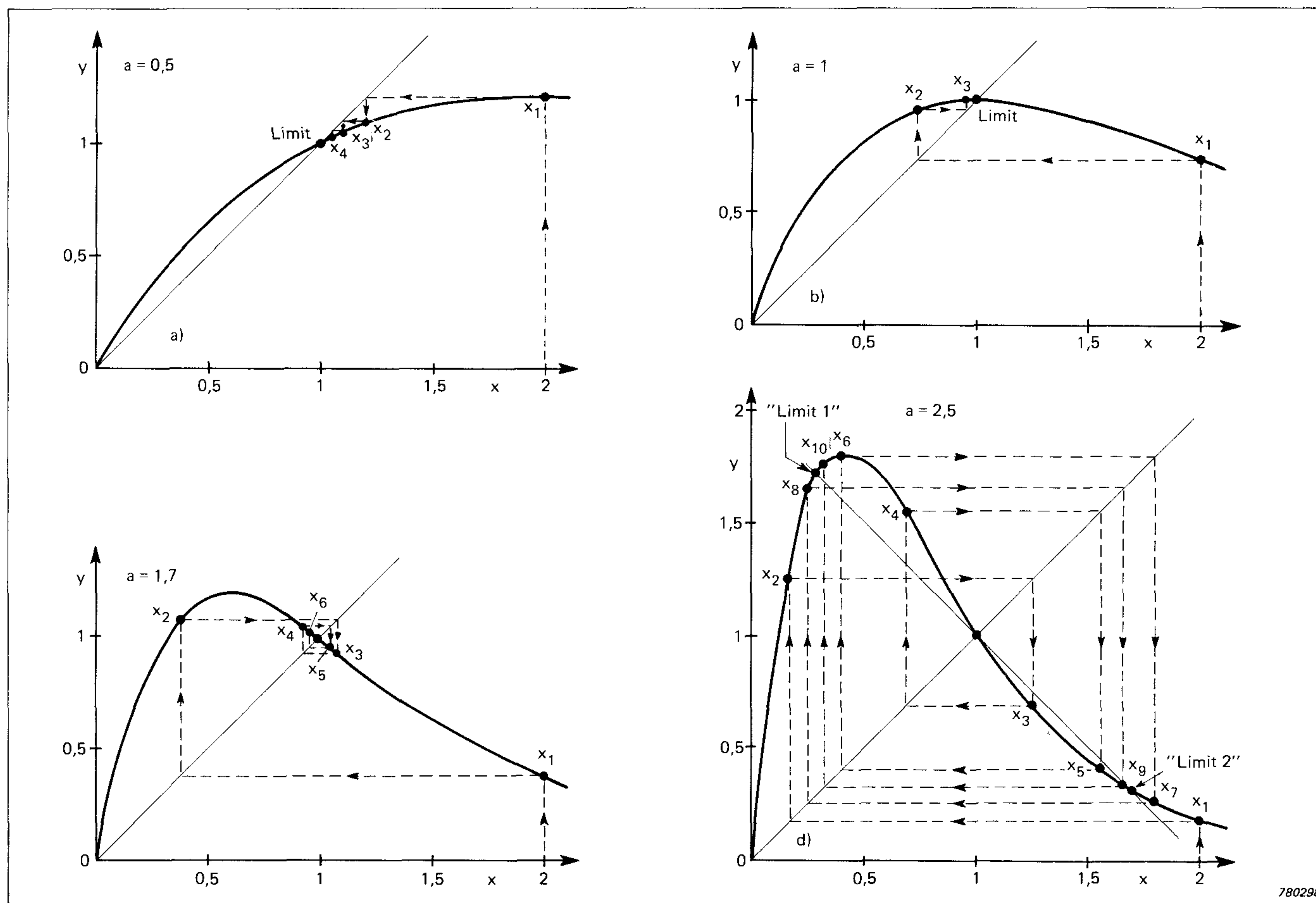

Fig.2. The compressor function for different values of a
a) a = 0,5 c) a = 1,7
b) a = 1 d) a = 2,5

$x = 2$. Eqn.(4) should therefore be replaced by $x_{n+1} = x_n \exp(-a)$. In practice, however, the level variation to be expected between two pulses is much smaller than 6 dB (see Appendix A). Hence only Eqn.(4) will be considered in the following.

Examining Eqn.(3) or (4), it is seen readily that if the series has one and only one limit, the limit is equal to 1. However, a condition for the series to converge towards the limit is that the slope of the function $x \exp.[a(1-x)]$ falls between -1 and $+1$ for $x = 1$, which gives the convergence condition:

$$0 < a < 2 \quad (5)$$

The fastest convergence is obtained when the slope at the limit is zero, i.e. $a = 1$. If a is greater than 2 the series does not converge any longer but tends to oscillate between two extreme values.

Fig. 2 shows the function $y = x \exp.[a(1-x)]$ for different values of a and illustrates how the series develop. Starting from x_0, x_1 is found on the y -axis. To find the next value again, the y -value must first be converted into an x -value; to do so, progress parallel to the x -axis until line $y = x$ is reached. From this point, progress parallel to the y -axis towards the curve and so on.

Fig.2d) illustrates the case where the series oscillates ($a > 2$) while Figs.2a) to 2c) show different con-

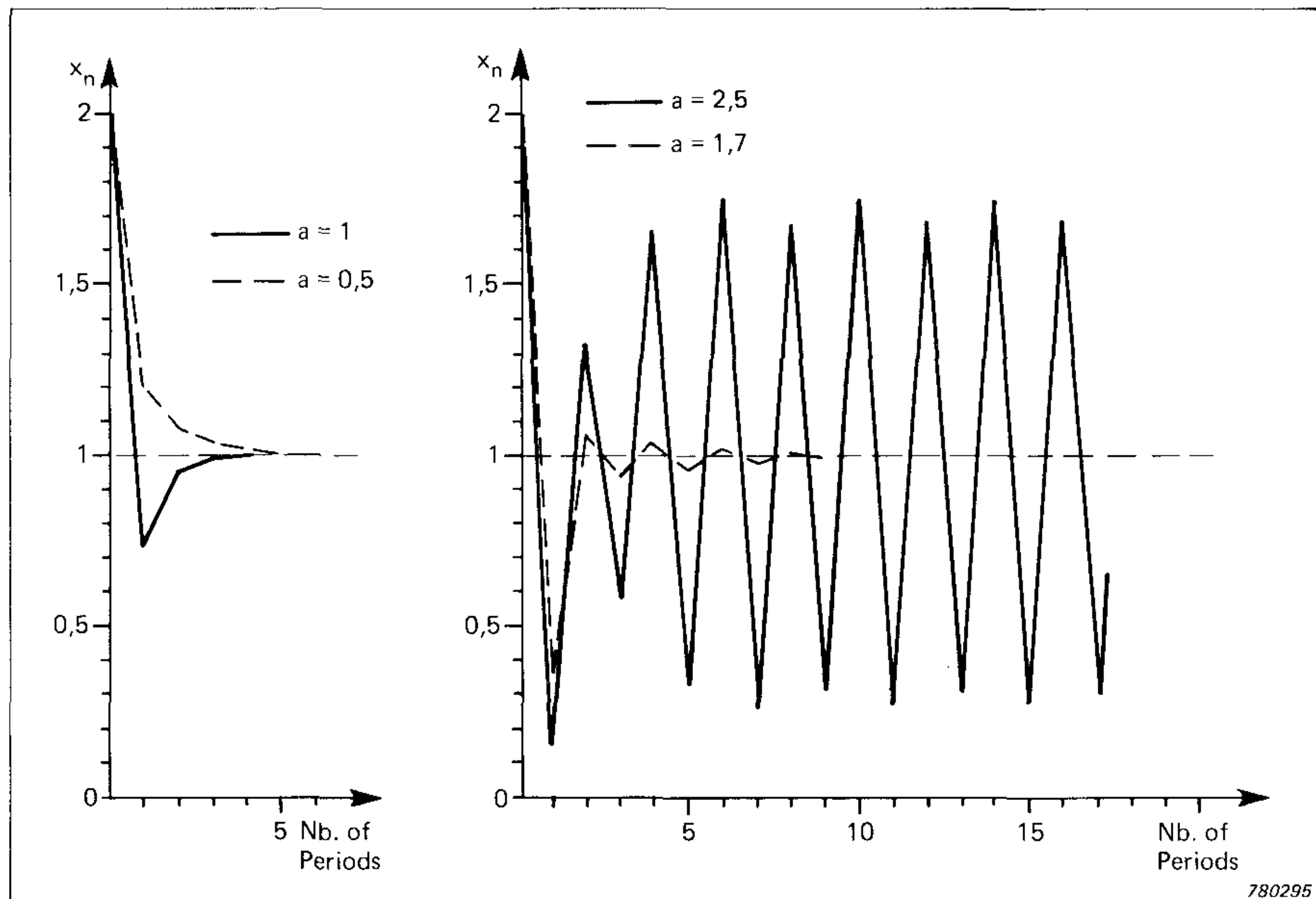

Fig.3. Variation of the compressor input voltage with time for a 6 dB gain increase at $t = 0$

a		0,5	0,8	1	1,25	1,5	1,7	1,8	1,9
Nb. of Periods	$\epsilon = 1\%$	6	3	3	3	4	8	13	26
	$\epsilon = 5\%$	3	2	2	2	4	4	6	11

Table 1. Number of periods necessary to obtain an error of less than 1% and 5% after a sudden gain variation of 6 dB

vergence conditions. It is seen that $a = 1$ gives the fastest convergence.

Fig.3 shows how the different series develop while Table 1 gives, for different values of a , the number of periods necessary to obtain a value which differs from 1 by less than 1% and 5% when starting from $x_0 = 2$.

As Fig.2b), Fig.3 confirms the previous statement that $a = 1$ gives the

C (dB/s)		10	30	100	300
T (ms)	a = 1	435	145	43,5	14,5
	a = 2	870	290	87	29

Table 2. Repetition period and compressor speed for $a = 1$ and $a = 2$

quickest convergence. Table 2 lists the repetition period of the bursts as a function of the selected compressor speed, both for $a = 1$ (optimum setting) and $a = 2$ (max. value).

Dynamic Range Considerations

When the 4440 triggers internally, the input voltage from the generator should be in the range 0,3 to 1 V RMS. The lower limit is set by the zero crossing detector. This gives a dynamic range of only 10 dB, which is normally not sufficient.

However, as two Gating Systems are used (one in the compressor loop and one in the measuring channel), one can be externally triggered by the other. This requires that the

generator provides both a normal output (regulated by the compressor circuit) and a constant level output, independent of the degree of compression. The constant level output drives one 4440 which, in turn, controls the triggering of the other 4440 which transmits the excitation burst. The arrangement requires good phase agreement between the two generator outputs. With the B & K Sine Random Generator Type 1027 this may be achieved by internal adjustment.

With the Sine Generator Type 1023, use should be made of the Constant Output Level Adaptor ZM 0200.

If the generator does not provide a constant level output, a compressor amplifier can be placed after the transmitting 4440. For example, use can be made of the compressor section of the B & K Noise Generator Type 1405.

Selection of Measurement Parameters

The theoretical repetition periods of Table 2 can only be considered as rough indications because of the spread in compressor speeds between generators (up to approx. 20%). To illustrate this, the set-up of Fig.4 was used in two ways: the control signal (chopped DC output of the 4440) was fed alternatively to the compressor circuit of the 1023 and of the 1405. The compressor speed was set to 30 dB/s in both cases. The gain in the compressor loop was varied by 10 dB up and down. Figs.5 and 6 show the variation of the compressor signal for different repetition periods. The curves show differences and it may be assumed that the reason is the actual difference in compressor speeds.

However, for most practical situations, a repetition rate of 10 to 15 Hz and a compressor speed of 30 dB/s will be suitable.

Another parameter to be considered is the sweep speed since it influences the offset error if the gain is continuously varying (see Appendix A). This is illustrated in Fig.7. The curves were recorded using the set-up of Fig.4 with the D-weighting network of the Measuring Amplifier switched in. Curve a) shows the frequency response of the D-weighting network for constant input voltage and curves b), c) and d) show the response when using a compressor loop (C = 30 dB/s, T = 65 ms) with different paper speeds. Curve b) illustrates best the influence of the slope of curve a) on the offset error. When the slope is zero, the error is also zero (e.g. between 500 Hz and 1 kHz, as well as between 4 kHz and 5 kHz). When the slope is positive, the offset is also positive and vice versa. Finally, when the slope is constant, the offset is also constant (e.g. between 1,5 kHz and 2 kHz).

It can be seen that a paper speed of 1 mm/s gives no noticeable offset error and can be used whenever the gain does not show strong irregularities.

For adjusting the compressor loop, it is good practice to first record the frequency response with-

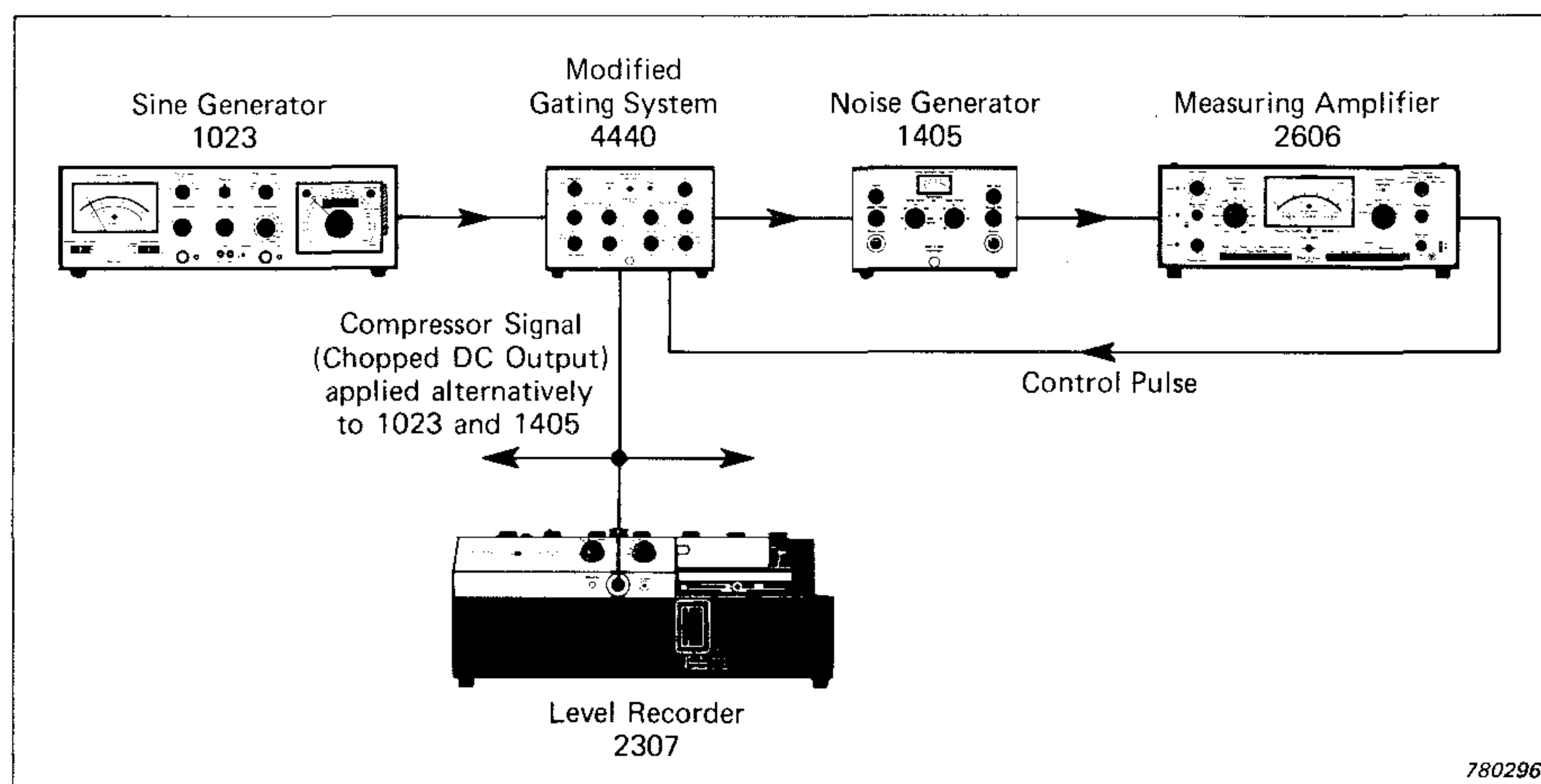

Fig.4. Set-up for investigation of the influence of compressor speed variation

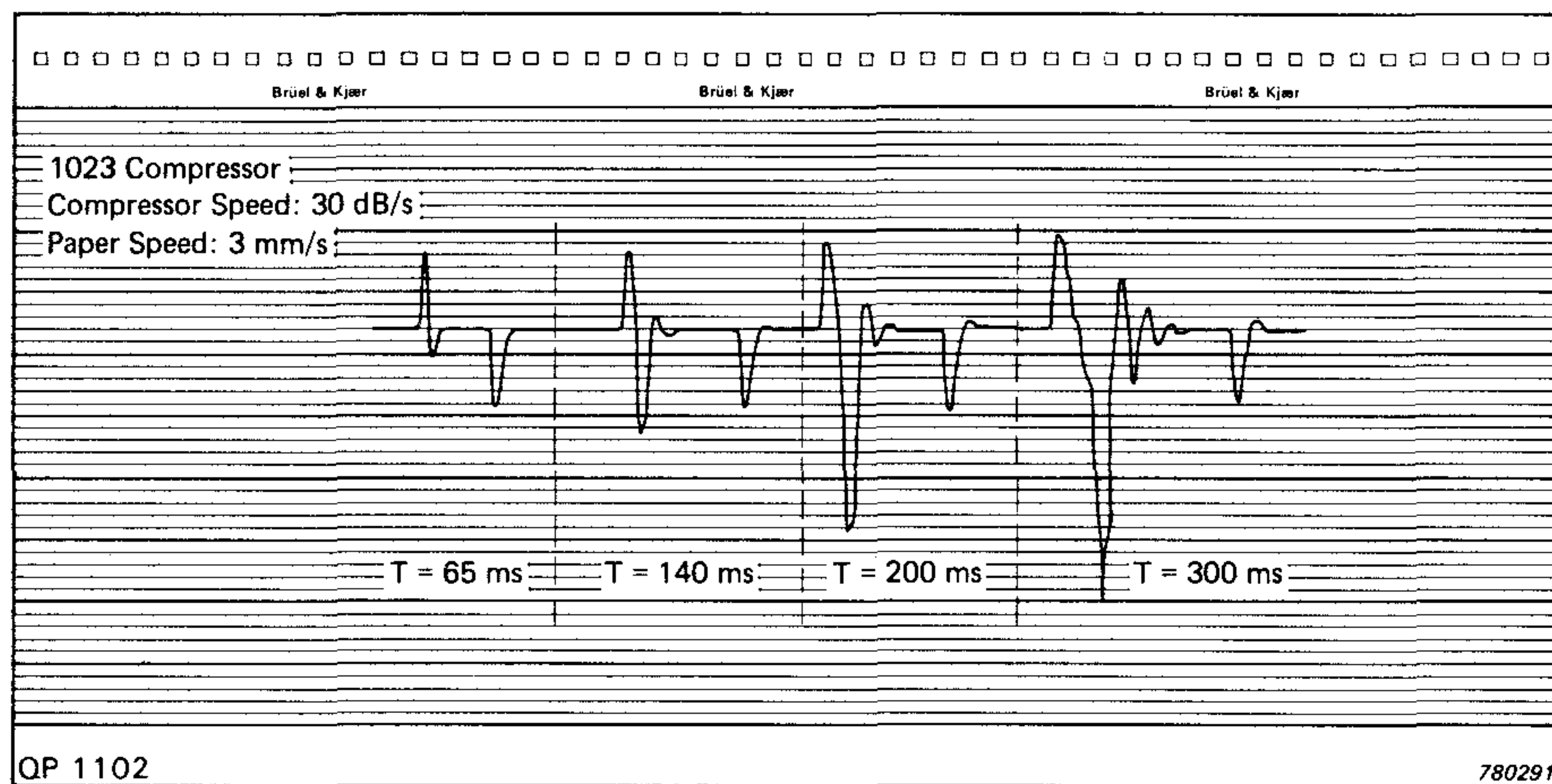

Fig.5. Typical compressor voltage variation after a 10 dB gain variation using the compressor of the Sine Generator Type 1023

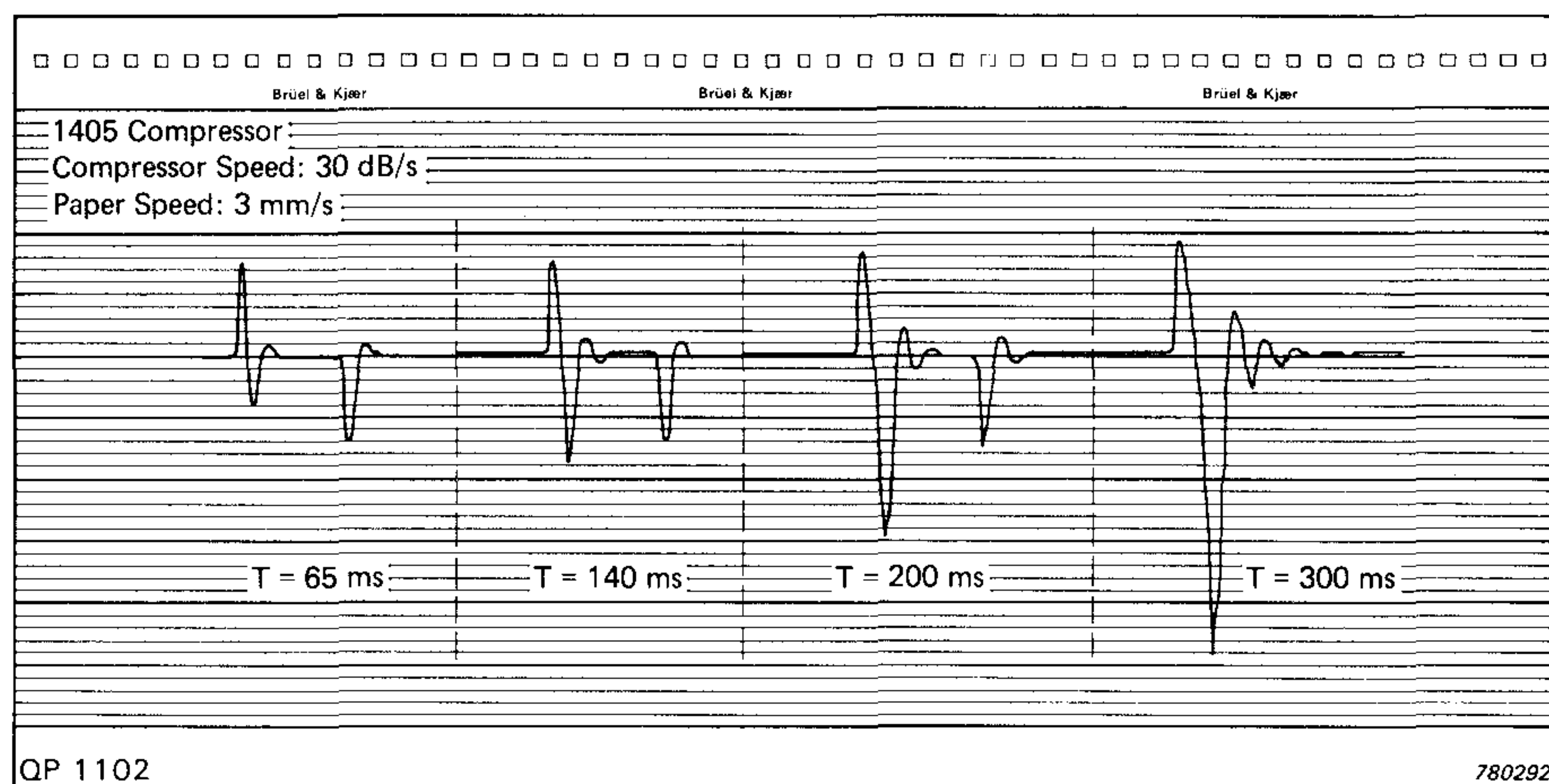

Fig.6. Typical compressor voltage variation after a 10 dB gain variation using the compressor of the Noise Generator Type 1405

out compression and then adjust the compressor at the frequency giving minimum response. This ensures that the compressor amplifier is not overloaded during the sweep.

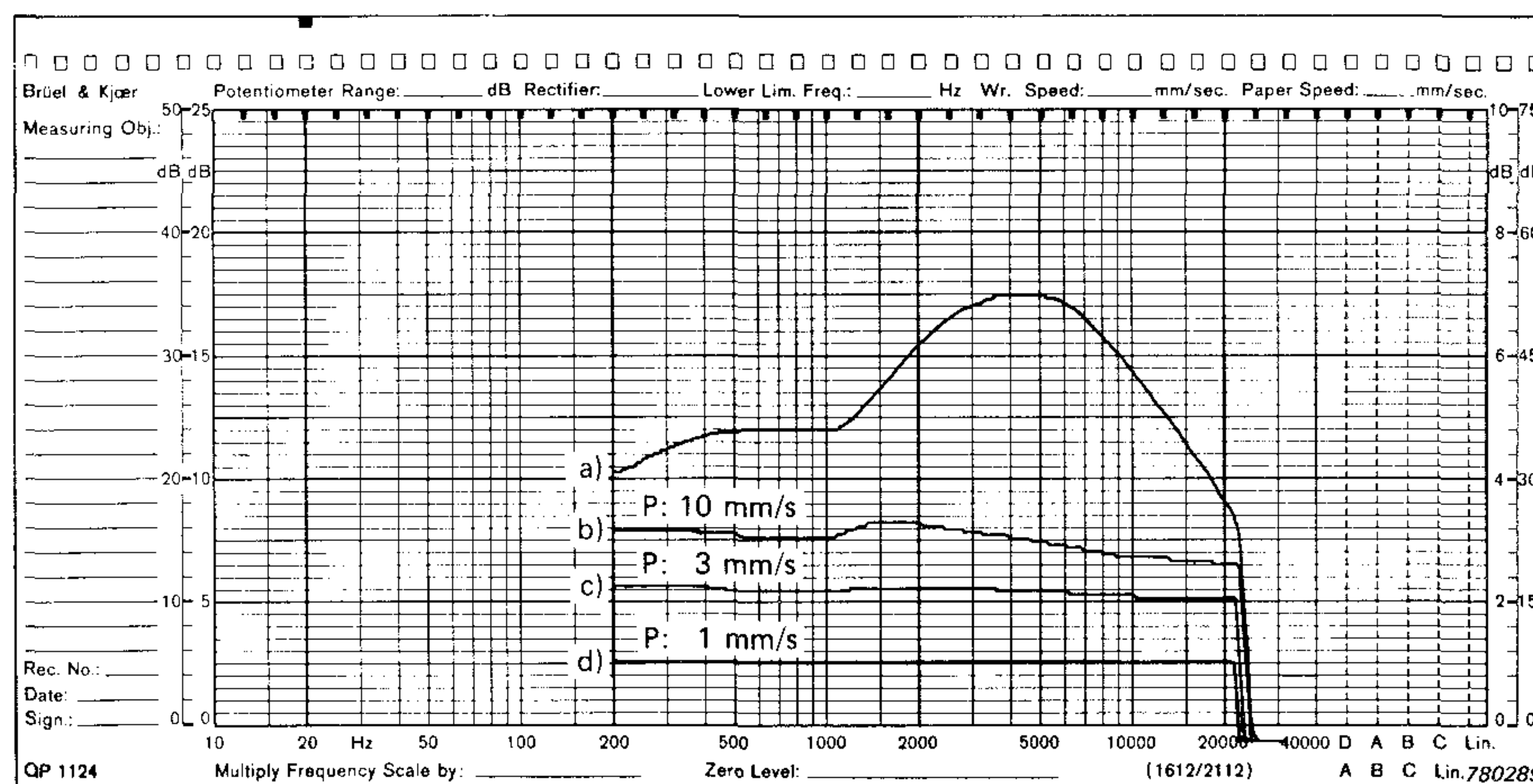

Fig.7. Influence of sweep speed

Application to Microphone Measurements

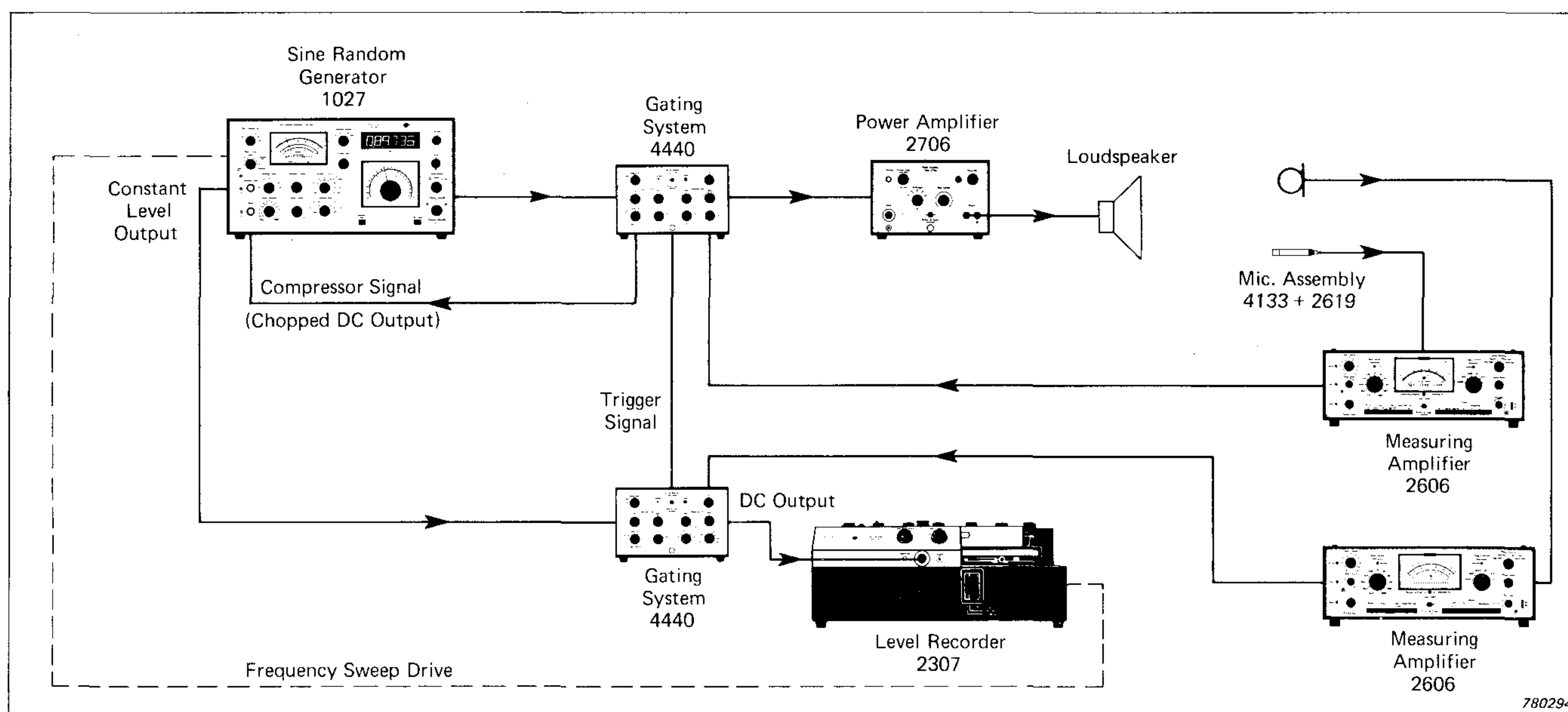

Fig.8. Typical set-up for microphone measurements

The use of gating technique in electro-acoustic measurements is common practice today (Reference 2) as it allows to achieve free-field conditions in ordinary rooms. The method is widely used for loudspeaker measurements, directivity measurements, etc.

To measure the frequency response of a microphone, the sound pressure level must be kept constant using a reference microphone to control the compressor loop. A typical measuring system is shown in Fig.8.

The system was adjusted for $C = 30 \text{ dB/s}$ and $T = 140 \text{ ms}$. Fig.9

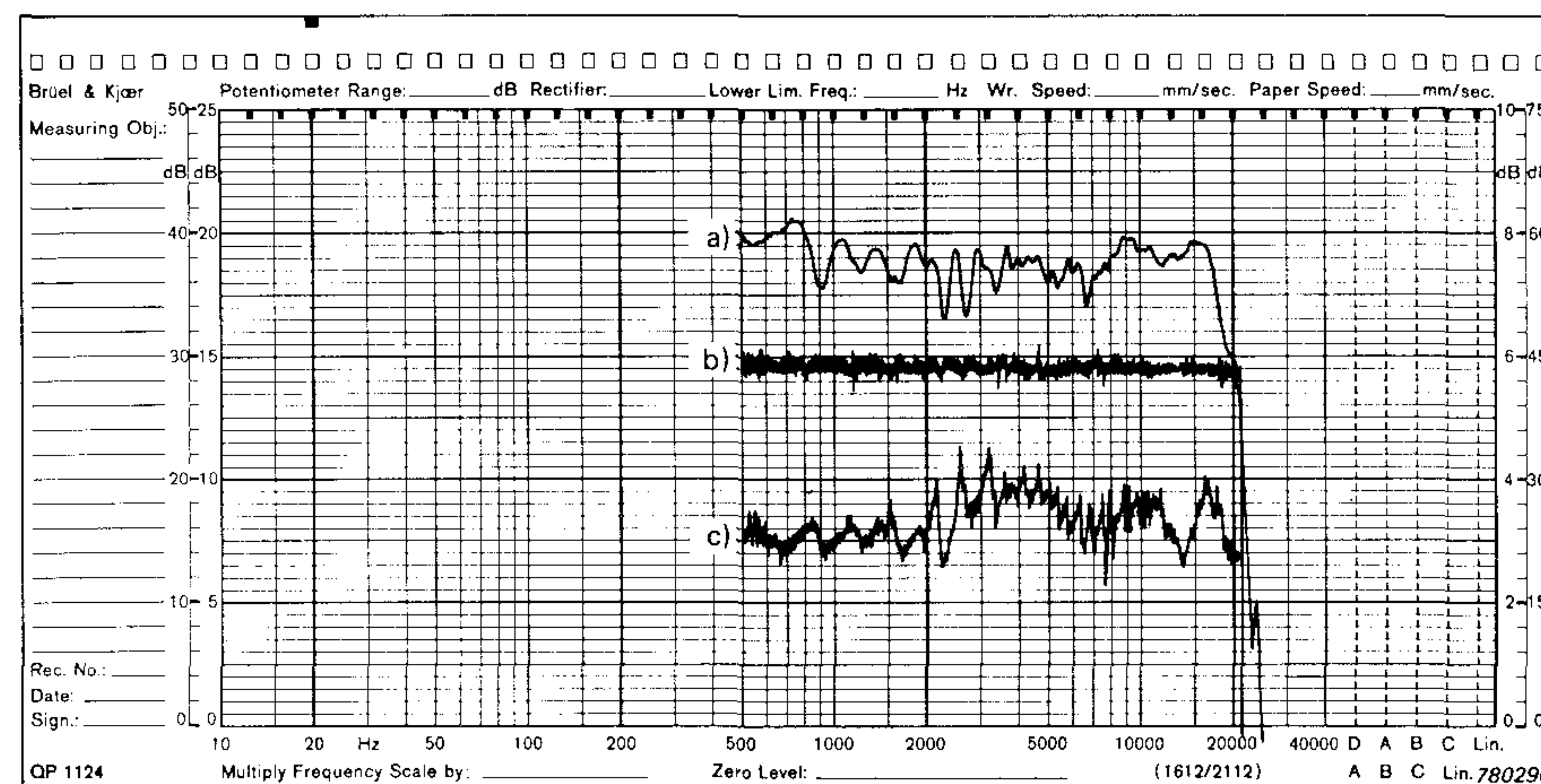

Fig.9. Microphone measurement results
a) Loudspeaker frequency response (without compression)
b) Output voltage of compressor microphone
c) Frequency response of test microphone

shows the measurement results. Curve a) is the frequency response of the loudspeaker with constant input level (without compression). Curve b) represents the output signal of the compressor microphone when the compressor is active while curve c) is the frequency response of the test microphone (small tape-recorder microphone). The small oscillations on curve b) are mainly due to large level variation between pulses. They can be reduced using a lower paper speed, as shown in Fig.10 where the paper speed was reduced from 1 mm/s to 0,3 mm/s.

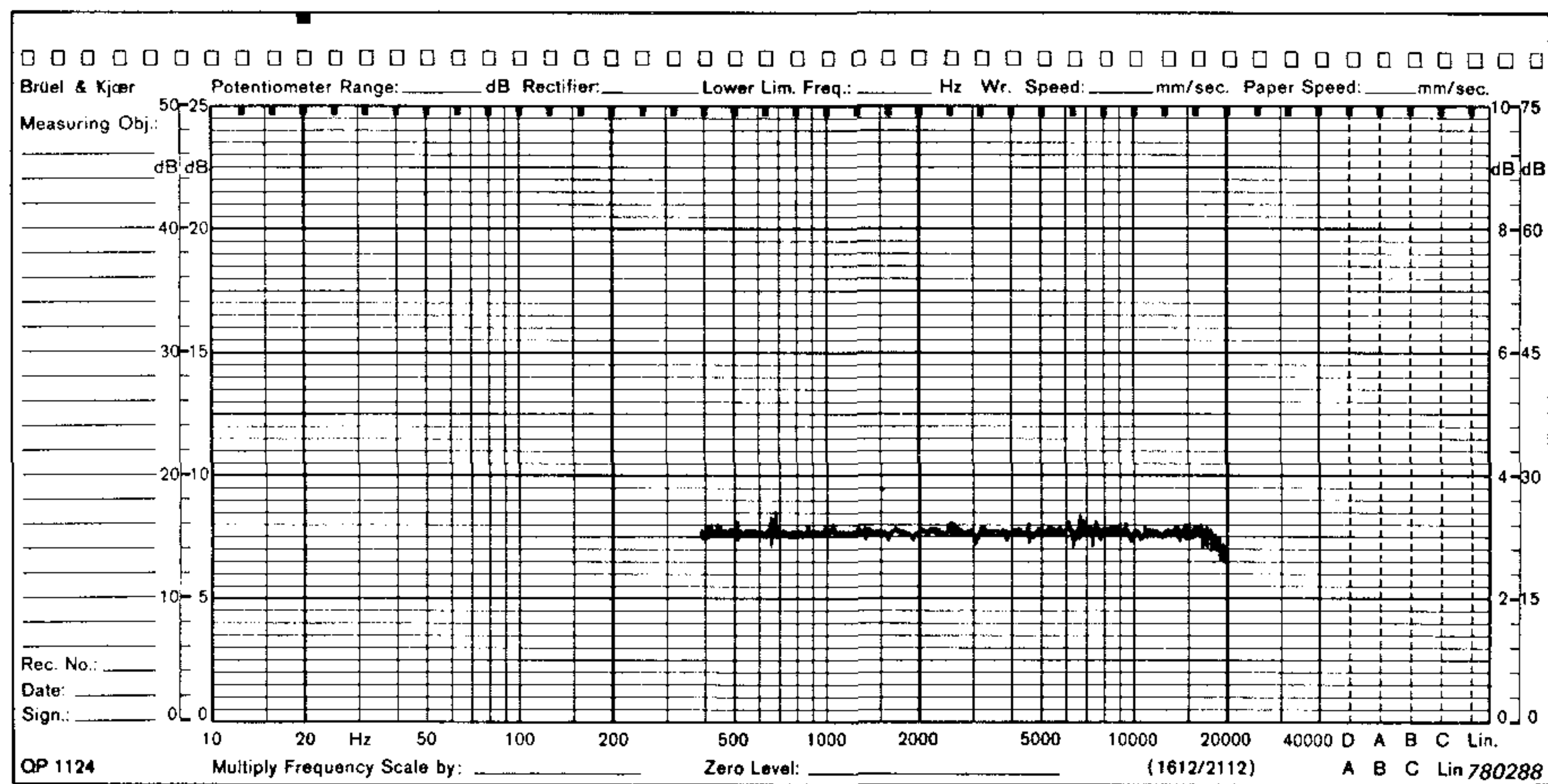

Fig.10. Output voltage of the compressor microphone with a lower paper speed

It should be underlined that the main purpose of the measurements was to confirm the possibility of applying compression techniques to

tone-burst measurements. The difference in sound level due to position differences, which is a well known problem in anechoic room

measurements (Reference 3), was not given special attention and would require further investigation.

Conclusion

Compression techniques can be applied to tone-burst measurements if the convergence condition is fulfilled. Combining the advantages of gating technique and compression technique it is possible to broaden the application domain of "free-field" measurements in ordinary environment. In electro-acoustics, ap-

plications may be microphone frequency response measurements, loudspeaker distortion measurements, etc. In the field of underwater acoustics, gating technique is often used for hydrophone measurements in small watertanks (Reference 4) and compression can be applied to compensate for the

12 dB/octave slope of the frequency response of a hydrophone when used as sound projector. Generally speaking, compression technique can be applied to tone burst measurements whenever a well-defined excitation signal is needed.

References

1. "Use of a compressor loop in tone-burst measurements with the High Pressure Microphone Calibrator Type 4221", by P. Bernard, B & K Application Note 15—127
2. "Electro Acoustic free-field measurements in ordinary rooms — using gating techniques", by H. Møller and C. Thomsen, B & K Application Note 17—196
3. "Free-field Response of Sound Level Meters" by P. Hedegaard, B & K Technical Review No.2-1976
4. "Introduction to Underwater Acoustics", B & K Application Note 16—047

Appendix A

Influence of Gain Variation

In the previous discussion static conditions were assumed. The gain was suddenly changed and remained at the new value. In practical systems, however, the gain will vary continuously, either with a constant slope (e.g. 12 dB/oct. for hydrophone measurements) or in a more complicated way.

At the beginning of the measurements, the system is balanced at a fixed frequency. A frequency sweep is then started and the gain of the system varies. Assuming a variation rate of G dB/s, the gain variation between two pulses is GT .

Hence

$$20 \log x_{n+1} = 20 \log x_n + 2CT(1 - x_n) + GT$$

or

$$x_{n+1} = x_n \cdot g \cdot e^{a(1 - x_n)}$$

with

$$g = e^{\frac{GT}{20M}}$$

The limit of this series is no longer 1 but

$$x_1 = 1 + \frac{G}{2C} \left(= 1 + \frac{\ln g}{a} \right)$$

The magnitude of the bias error may be estimated from a practical example, using $a=1$ (i.e. $C=30$ dB/s, $T=140$ ms). Assuming a logarithmic sweep of the generator, 1 mm on the recording paper of a B & K Level Recorder corresponds to 1/15 octave. If the slope of the system is N dB/oct. and with a paper speed of P mm/s, the limit is equal to

$$x_1 = 1 + \frac{G}{2C} = 1 + \frac{N P}{2 \times 30 \times 15} = 1 + \frac{N P}{900}$$

Table A1 gives x_1 as a function of the slope for $P=1$ mm/s. The bias error, in dB, is also given. It is seen that the error can be neglected in most cases. Note that it can be made even smaller by selecting a lower paper speed. (Refer also to Fig.7.)

Slope dB/oct.	Limit x_1	Error dB
(+) 6 (-)	1,0067 0,9933	+ 0,06 -0,06
(+) 12 (-)	1,0133 0,9867	+ 0,12 -0,12
(+) 24 (-)	1,0267 0,9733	+ 0,23 -0,23
(+) 36 (-)	1,0400 0,9600	+ 0,34 -0,35
(+) 48 (-)	1,0533 0,9467	+ 0,45 -0,48

Table A1. Bias error as a function of response slope

Appendix B

Influence of Time Delay

The influence of time delay on the compression characteristics of the system is due to the fact that the compressor transducer receives pulses which are representative of the generator output a certain time (τ) before. See Fig.B1.

When x_n is received, the rate of change of the compressor becomes

$$S_n = 2 C (1 - x_n)$$

At this instant, the output of the generator is no longer x_n , but has changed by τS_{n-1} . From this value, the generator output varies with the new rate of change, S_n , until a new pulse is transmitted, which occurs $T - \tau$ seconds after. The new level is therefore equal to:

$$20 \log x_{n+1} = 20 \log x_n + 2 C \tau (1 - x_{n-1}) + 2 C (T - \tau) (1 - x_n)$$

$$x_{n+1} = x_n \exp. [a(1 - x_n)] \cdot \exp. \left[a \frac{\tau}{T} (x_n - x_{n-1}) \right]$$

The "error" term, $\exp[a \tau/T(x_n - x_{n-1})]$ is governed by τ/T . Its influence may be illustrated as follows. Taking $a=1$, it is assumed that the system is balanced ($x_0 = 1$) and that the gain is suddenly increased by 6 dB ($x_1 = 2$). Table B1 gives, for different values of τ/T ,

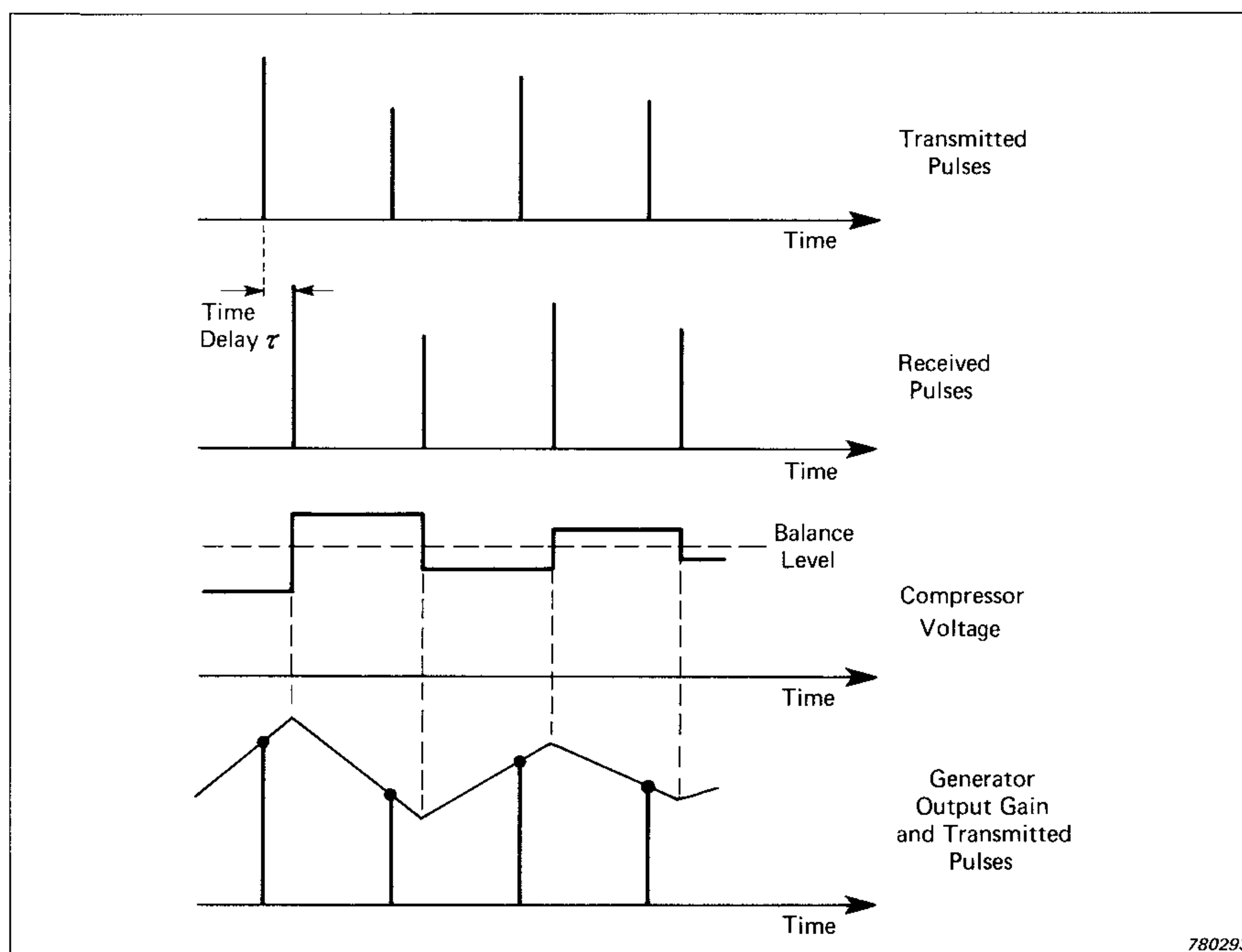

Fig.B1. Influence of time delay

τ/T		0	0,01	0,05	0,08	0,1	0,15	0,2	0,5
No. of Periods	$\epsilon = 1\%$	3	3	3	3	5	5	6	12
	$\epsilon = 5\%$	2	3	3	3	3	3	3	9

Table B1. Influence of time delay on the convergence speed

the number of periods necessary for the voltage to come back to the balance level with an error of less than 1% and 5%. It is seen that if τ/T is less than 0,1, the necessary num-

ber of periods is the same as if there was no delay. In the practical case described, the time delay is approx. 3 ms, which has no noticeable influence on the measurements.

